



PENWOOD

WOOD COMPOSITE DOOR AND WINDOW SYSTEMS

**THANKS TO THE 100% RECYCLABLE
PENWOOD PROFILE PRODUCTION,
PENWOOD DOORS AND WINDOWS
ARE ENVIRONMENT-FRIENDLY.**





We have minimised the costs by cutting-edge, unique and patented technology of Adopen.



We eliminated the costs arising from metal reinforcement.

We provided practicality with a single supply point.

We provided great convenience with a single payment point.

We saved money on transportation.

We eliminated the *use of metal reinforcement.*

As the use of metal reinforcement were no longer required, we reduced the labor costs at the workshop.

No need for extra storage space

There is no need to cut the metal reinforcement in areas corresponding to the window handles. Easy cutting, easy application.

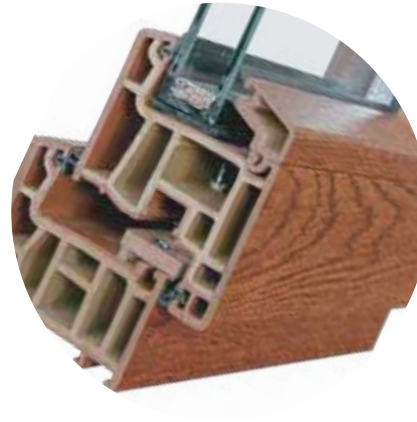

No need for extra storage space

This is the end of reserving separate spaces for reinforcement profiles and the profiles, the end of rust and dirt. With the Penwood technology, all manufactured profiles can be stored as a whole.

We got rid of separate machines *for cutting and screwing.*

Reduced labor costs

Thanks to its practicality, we were able to get rid of long and exhausting processes and we created a more efficient working process.



We are saving your time

Thanks to its practicality and ease of application, no more spending hours for window manufacturing.



We've achieved excellent *strength in the corners.*

Penwood technology ensures that inner walls of the Penwood profiles are also welded, resulting in higher strength value in the corners.

This performance cannot be achieved with regular profile systems, as metal reinforcements used with regular profiles cannot be welded in the corners.

Approximate Corner Strength Value
according to TS EN 514

5,2 kN

1 kN = 100 kg

We have achieved the highest performance values in the tests.

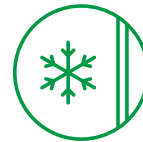
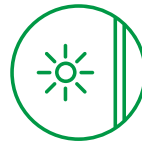

A game - changing innovation brought to you by **ADOPEN: PENWOOD WINDOWS.**

- *The revolutionary new product PENWOOD, a patented product of ADOPEN, is a unique product which eliminates the need for metal reinforcement profile, provides an excellent insulation in every climatic condition and reduces labor cost.*
- *Penwood is a 100% recyclable environment-friendly product thanks to its raw materials.*
- *It has superior insulation properties due to the combination of the natural structure of wood and high technology production.*
- *With its UV and UF values (heat insulation) in European standards, they are more practical than other products on the market.*
- *Thanks to its high insulation values, it is an economical product because it prevents heat loss and exchange inside the building.*
- *All tests performed against all kinds of climatic conditions (heavy rain, snow, cold, wind, high temperature, etc.) have been successful.*

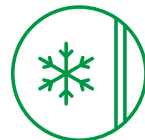
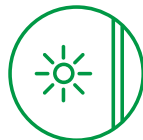
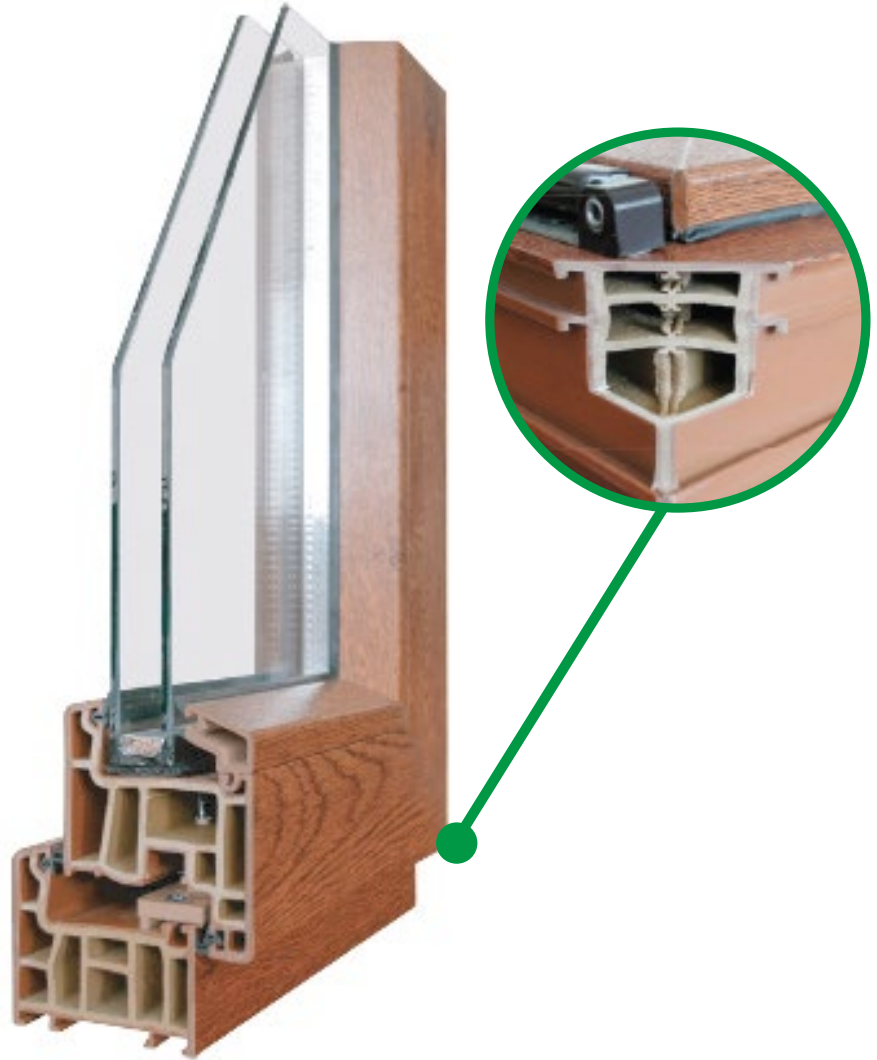

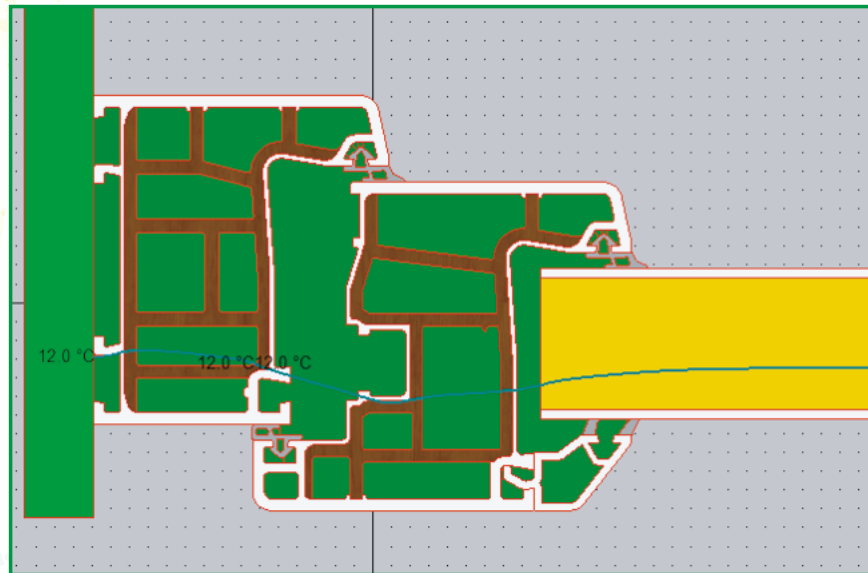
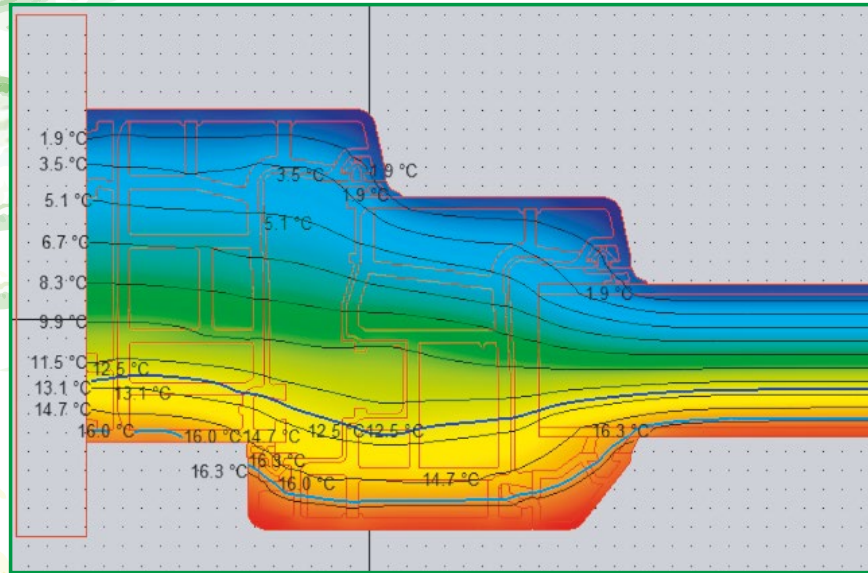

TECHNICAL SPECIFICATIONS

Thermal transmittance (Uf) computation performed in accordance with EN ISO 10077-2:2017

Transmittance (Uf)	1,1 W/m ² K
Transmittance (Uw)	0,89 W/m ² K
Profile	70 mm
Class	B Class
Glass Thickness	4-20-24-28-32-36-42 mm

CUTTING

There is no need to make any changes to the machine settings in the Penwood system, as windows are cut in the manual single head-double head cutting machines, including automatic cutting - machining center.

HANDLE AND WATER DISCHARGE

In the Penwood system, there is no need to make any adjustment changes in the water discharge and handle hole drilling machines, including automatic machining center, without disrupting the current system

PROFILE END MILLING

In the Penwood system, milling process is performed without having to make any adjustment changes in the current profile end milling machine and W750 profile blades, including multiple profile end milling machines.

CORNER WELDING

In the Penwood system, welding is done by using welding moulds present in the single-double head CNC 4 head welding machines. Only weld time and melt down period has to be adjusted. Weld time varies from machine to machine, melting temperature is 240 and melting time is 28 secs and standby time is 30 secs. In addition, no different settings are required in the machine. Average corner weld strength value according to EN 514 is 5 kN (1 kN = 100 Kg.)

CORNER CLEANING

In Penwood profiles, corner cleaning blades of current series profiles are the same and used commonly. At the same time, no changes to the CNC corner cleaning settings are required.

MULLION CONNECTION

In the Penwood systems, standart series mullion connectors are used. The most important issue here is to use the 3,9x32 mm YHB espagnolette screw when connecting the connectors to profile end and door case. In addition, a 4,7 x 60 mm puller screw should be placed on the profile end from the door case. The screws hold double curtains in the profile, so the single screw can carry loads up to 450 kg.

SASH ASSEMBLY

In the Penwood system, in the hinge, case and sash assembly, the usage of a YHB espagnolette screw of 3,9x38 mm is mandatory. Self-drilling screws should never be used. It is mandatory to use a YHB espagnolette screw of 3,9x25 mm when making an espagnolette connection in the Penwood system. Self-drilling screws should never be used.

**With Penwood system profiles, profile bending can also be performed and thus strength and endurance in all parts of the profile is maintained.*





CENTRUM STAVEBNÍHO INŽENÝRSTVÍ a.s.
(Building Engineering Centre, joint-stock company)
Workplace in ZLÍN, K Čáslavě 304, 764 32 ZLÍN - Louky

issues to

Applicant: **ADOPEN PLASTİK ve İNŞAAT SANAYİ A.Ş.**
Organize sanayi 2. Etap
Antalya, Türkiye

CERTIFICATE

Of the product characteristic

No. CV – 13 – 433/Z

Product: **Composite tilt and turn window, 752 PENWOOD system**

Manufacturer: See Applicant

Description:

Frame and sash	Frame - 77109-11000, composite material (PVC + wood); sash - 77109-15000, composite material (PVC + wood)
Other profile	Glazing bead 20101-07600 with coextruded sealing
Glazing	Double glass unit: EUROFLOAT 4 mm/ENplus – spacer TGI 10 mm, argon 90 – EUROFLOAT 4 mm – spacer TGI 10 mm, argon 90 – ENplus/EUROFLOAT 4 mm; $U_g = 0.8 \text{ W/(m}^2\cdot\text{K)}$
Sealing	inner – 34024 - 32021; outer gasket – 34024 - 31021; infilling panel outer gasket – 34024 - 31021
Drainage and decompression	Drainage and decompression of the sash – 2 holes with (30 x 5) mm size, frame drainage – 3 intake holes with (30 x 5) mm size and 2 outlet holes with (30 x 5) mm size, decompression of the frame – 2 intake holes with (30 x 5) mm size
Hardware	All-Peripheral hardware – ROTO NT, 10-point closure, safety-catch, handle

Result:

Title of tested parameter	Testing method	Result
Thermal transmittance U_i	ČSN EN ISO 12567-1	1,1 $\text{W/(m}^2\cdot\text{K)}$

This Certificate proves the conformity of above given product properties with the required standard values:

Fulfills the standard ČSN 73 0540, part 2 - for recommended thermal transmittance	$U_{i,0.23} \leq 1,2 \text{ W/(m}^2\cdot\text{K)}$
--	--

Background documents: Test report No. 184/13, CSI, s.s. Zlín, AQ 212

This Certificate applies only for a product which its specification is given in the test report in detail. It certifies only above given properties and neither implies nor substitutes certification in accordance with the Law No. 22/1997 Coll. on technical requirements for products.



Ing. Zbislav Panovec, ČSc.
Workplace head

Issue date: **25.6.2013**
Valid till: **25.6.2015**
Elaborated by: Ing. Nizar Al-Hajar

Savybių klasifikacija MLTB-1579-2015-I C



pradiniai (ITT) tipo tyrimai pagal PN-EN 14351-1+A1:2010
Vertinimas statybos produkto eksploatacines savybes pagal bandymus/skaiciavimus.

Notified body NB 2109

Įmonė: **UAB "Aulaukis"
Pramones G 3
LT-35100 Panevezys
Lietuva**

Gaminys: Vienos dalies langas (1,23 x 1,48 m) pagamintas iš PVC-U sistemos profilių
Wintech-Penwood 752
Ataskaitoje pristatomi tyrimų rezultatai yra gauti tyrimų, nurodytų užsakyje nr.
MLTB-1579-2015, metu.



Tyrimų metodai
Šilumos izoliacija
PN-EN ISO 10077-1



Garsi izoliacija
PN-EN 14351-1+A1 Priedas B

Klasifikacinės normos:	PN-EN 14351-1 + A1:2010	IGU
	Nurodo dimensija 1230 x 1480	3(-1; -5) dB
	Uw	pasivertus [m ²] iki ≤ 2,7 33(-1; -5) dB nuo 2,7 iki ≤ 3,6 32(-1; -5) dB nuo 3,6 iki ≤ 4,6 31(-1; -5) dB virš 4,6 30(-1; -5) dB
	Wint'K	Rw(C,Ctr)dB

Pastabos: skaičiavimai už stiklo pakelių 4/14/4/14/4.

Mobilne Laboratorium Techniki Budowlanej Sp. z o. o.

1) vertinimas eksploatacines savybes padarė *Laboratorijos vadovas Mściwickowski Adam*
2) bandymų padarė *specialistas skaičiavimai Danuta Roszkowska*

20-02-2015, Włobrzych

CE
modelis ženklų
„Gaminio patikrinimas ženklu CE reikšia, kad atitinkamas asmuo (fizinis arba juridinis) deklaruoja, kad gaminyje atitinka visus jam galiojančius ES reikalavimus bei, kad buvo atliktos visos būtinos atitinkamumo įvertinimo procedūros.“

Revizoriai PN-EN 14351-1+A1:2010 p. 7.5 Priedas pradžioje ir pabrėžtinomis PPC (ZNP) gamintojas privalo atlikti ZNP patikrinimą bei visus einamuosius tyrimus ir kontrolinius tyrimus mažiausiai kartą per metus. Pagal tyrimų planą atliekamas kartotinis patikrinimas bei paties gamintojo produktų savybes taip pat ir produktų, kuriuos gamina ITT tyrimų metu.



Mobilne Laboratorium Techniki
Budowlanej Sp. z o. o.
NIP PL 6862998350
REGON 020573002
KRS 0000461727

58-300 Włobrzych, ul. Jana Kasprowicza 21 lok. 2
tel.: +48 74 640 14 63, fax: +48 74 601 41 40
http://www.badaniaoekien.pl
e-mail: biuro@badaniaoekien.pl

Notyfikavimas įstaiga (notified body) NB 2109

Savybių klasifikacija
MLTB-1579-2015-I A



pradiniai (ITT) tipo tyrimai pagal PN-EN 14351-1+A1:2010
Vertinimas statybos produkto eksploatacines savybes pagal bandymus/skaiciavimus.

Notified body NB 2189

Įmonė: UAB "Aulaukis"
Pramones G 3
LT-35100 Panevezys
Lietuva

Gaminys: Vienos dalies langas pagamintas iš PVC sistemos profilių
Wintech-Penwood 752
Ataskajoje pristatomi tyrimų rezultatai yra gauti tyrimų, nurodytų užsakyme nr. MLTB-1579-2015, metu.



Tyrimų metodai	Oro pralaidumas PN-EN 12207	Nepralaidumas vandeniui PN-EN 12208	Atsparumas vėjui PN-EN 12211	Aprauginių įranginių kėlėjų galia PN-EN 14609
Klasifikacijos normos	PN-EN 12207:2001	PN-EN 12208:2001	PN-EN 12211:2001	Ribinė vertė
 1230 x 1480	4	5A	C3	350 N

Mobilne Laboratorium Techniki Budowlanej Sp. z o. o.

- 1) vertinimas eksploatacines savybes padare *Laboratorijos vadovas Mscichowski Adam*
2) bandymų padare *aukšto rango technikas Domański Adam*
technikas Łoziński Marek

22-01-2015, Włbrzych

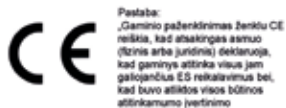

modelis ženklui CE

Remiantis PN-EN 14351-1+A1:2010 p. 1.5 Prasto profiliai ir patalpinimas PVC (DVP) gamintojas privalo žvilgtelėti bei visuose etapuose tyrimus ir sertifikavimo etapus kartą per metus. Pajam tyrimų planą atitinkantis sertifikatas bus gautas gamintojų produktų savybes kaip ir produktų sertifikavimą ITT tyrimų metu.

 Mobilne Laboratorium Techniki Budowlanej Sp. z o. o.
NIP PL 886208350
REGON 020573602
KRS 0000461727

58-300 Włbrzych, ul. Jana Koszowicza 21 lok. 2
tel. +48 74 840 14 63, fax: +48 74 661 41 40
http://www.badaniaokien.pl
e-mail: biuro@badaniaokien.pl

Notyfikowana jednostka (notified body): NB 2189

CLASSIFICATION OF PROPERTIES
Nr B/MLTB-935-2013



for Initial Type Testing (ITT) consistent with the norm PN-EN14351-1+A1:2010

Notified body NB 2189

Annex to the reports from the tests.



Company: Adopen Turkey
Organize Sanayi Bölgesi 2. Etap, 07040 Antalya, Turcja

Product: Window and balcony door made from PVC-UJ profiles of system
PENWOOD 752

Test results are included in the following test reports registered under the number of the request MLTB-935-2013



Testing methods: Air permeability PN-EN 12207, Waterproofness PN-EN 12208, Wind load resistance PN-EN 12211, Security equipment capacity PN-EN 14609, Acoustics PN-EN 14351-1+A1 Annex B

Classification standards	PN-EN 12207:2001	PN-EN 12208:2001	PN-EN 12211:2001	Threshold value
 1000 x 2300	4	7A	C4	350 N IGU 300-1, -4) dB surface [m ²] to < 2.7 33(-1, -5) dB from 2.7 to < 3.6 32(-1, -5) dB from 3.6 to < 4.6 31(-1, -5) dB above 4.6 30(-1, -5) dB Rw(C,Cb)dB
 1500 x 2300	4	8A	C1 B2	
 2301 x 1600	4	8A	C3 B4	

Remarks: Enveloped hardware Accado

Mobilne Laboratorium Techniki Budowlanej

Head of laboratory *Adam Mscichowski*

Włbrzych, day 28-06-2013

Consistent with PN-EN 14351-1+A1:2010 point 1.5 Factory production control (FPC) (DVP) the producer should carry out FPC assessment together with control and quality control inspection of a product at least once a year. The inspection conducted in accordance with the inspection plan should confirm that the manufactured products have the same properties as the products subject to ITT. The Classification of Properties above becomes invalid when there is a change of production technology or a change of components used for the production of a tested product.

 Mobilne Laboratorium Techniki Budowlanej Sp. z o. o.
NIP PL 886208350
REGON 020573602
KRS 0000461727

58-300 Włbrzych, ul. Jana Koszowicza 21 lok. 2
tel. +48 74 840 14 63, fax: +48 74 661 41 40
http://www.badaniaokien.pl
e-mail: biuro@badaniaokien.pl

Notyfikowana podroczka (notified body): NB 2189



00-611 Warszawa, ul. Filtrowa 1, tel.(22) 825-04-71, fax (22) 825-52-86



Instytut Techniki Budowlanej
ZESPÓŁ LABORATORIÓW BADAWCZYCH
akredytowany przez Polskie Centrum Akredytacji
certyfikat akredytacji
nr AB 023



Strona 1 z 10

ZAKŁAD KONSTRUKCJI I ELEMENTÓW BUDOWLANYCH
LABORATORIUM KONSTRUKCJI I ELEMENTÓW BUDOWLANYCH

RAPORT Z BADAŃ NR LK01-0998/13/Z00NK

Klient:

ADOPEN PLASTIK VE INSAAT SAN. A.S

Adres klienta: ORGANİZE SANAYİ BOLGEŞİ ANTALYA/ TURCJA

Informacje dotyczące obiektu badań

Obiekt badań:	Kształtowniki okienne i drzwiowe z PVC-U systemu WINTECH PENWOOD
Inne informacje dotyczące obiektu badań:	Kształtowniki białe, białe okleinowane oraz barwione w masie okleinowane
Data przyjęcia obiektu badań:	09.05.2013r., 31.05.2013.
Nr protokołu przyjęcia obiektu badań:	LK00-0998/13/Z00NK, LK01-0998/13/Z00NK,
Procedura przyjęcia obiektu badań:	Procedura Zarządzania PZ ZLB 18

Informacje dotyczące badań

Data rozpoczęcia badań:	12.04.2013r
Data zakończenia badań:	03.06.2013r
Inne informacje dotyczące badań:	
Dokument odniesienia:	PN-EN 12608:2004, ZURT-15/III.04/2007

Metoda badania akredytowana:

PB LL-047/02/04-2008	Sprawdzenie wyglądu zewnętrznego, kształtu, wymiarów i prostoliniowości kształtowników z PVC
PN-EN 12608:2004	Kształtowniki z nieplastyfikowanego poli(chloruwinylu) (PVC-U) do produkcji okien i drzwi. Klasyfikacja, wymagania i metody badań
PN-EN 514: 2002	Kształtowniki z niezmiekczonego poli(chloru winylu) (PVC-U) do produkcji okien i drzwi. Oznaczenie wytrzymałości zgrzewanych naroży i połączeń w kształcie T.

Dokumenty związane:

ZURT-15/III.04/2007	Kształtowniki z nieplastyfikowanego polichloru winylu (PVC-U) foliowane, współwylaczane z warstwą akrylową PMMA lub z powłokami, do produkcji okien i drzwi balkonowych
---------------------	---

Wykonawcy badań:

Inż. Daniel Kuna

Praca badawcza dotycząca kształtowników z PVC-U systemu WINTECH PENWOOD na zgodność z normą PN-EN 12608:2004 - kształtowniki białe i ZURT-15/III.04/2007 - kształtowniki okleinowane

CZĘŚĆ 3. Badania starzeniowe profili białych, białych okleinowanych oraz barwionych w masie okleinowanych

Nr pracy:

0998/13/Z00NK

(LK04-0998/13/Z00NK)

Warszawa, styczeń 2014 r.



00-511 Warszawa, ul. Filrowa 1, tel.(22) 825-04-71, fax (22) 825-52-86

Praca badawcza dotycząca kształtowników z PVC-U systemu WINTECH PENWOOD na zgodność z normą PN-EN 12608:2004 - kształtowniki białe i ZURT-15/III.04/2007 - kształtowniki okleinowane

CZĘŚĆ 1. Badania fizyko-mechaniczne kształtowników białych

Nr pracy:
0998/13/Z00NK (LK02-0998/13/Z00NK)

Warszawa, styczeń 2014 r.

NARODOWY INSTYTUT ZDROWIA PUBLICZNEGO
– PAŃSTWOWY ZAKŁAD HIGIENY
NATIONAL INSTITUTE OF PUBLIC HEALTH
– NATIONAL INSTITUTE OF HYGIENE
ZAKŁAD HIGIENY KOMUNALNEJ
DEPARTMENT OF ENVIRONMENTAL HYGIENE

24 Chocimska 00-791 Warsaw • Phone (22) 5421354; (22) 5421349 • Fax (22) 5421287 • e-mail: sek-zhk@pzh.gov.pl

ATEST HIGIENICZNY **HK/B/0700/01/2009**
HYGIENIC CERTIFICATE **ORYGINAL**

Wyrób / product: **Profil okienny PCV**

Zawierający / containing: kompozyt PVC, stabilizator na bazie cinku i inne składniki wg dokumentacji producenta

Przeznaczony do / destined: produkcji okien PCV

Wymieniony wyżej produkt odpowiada wymaganiom higienicznym przy spełnieniu następujących warunków / is acceptable according to hygienic criteria with the following conditions:
- bez zastrzeżeń

Wytwórca / producer:
Adopen Plastic Ind. o
Organize Sanayi Bolgesi 2. Etap
Antalya, Turcja

Niniejszy dokument wydano na wniosek / this certificate issued for
Adopen Polska Sp. z o.o.
91-403 Łódź
ul. Zgierska 250/252

Atest może być zmieniony lub unieważniony po przedstawieniu stosownych dowodów przez którąkolwiek stronę. Niniejszy atest traci ważność po lub w przypadku zmian w recepturze albo w technologii wytwarzania wyrobu.
The certificate may be corrected or cancelled after appropriate motivation. The certificate loses its validity after or in the case of changes in composition or in technology of production.

Data wydania atestu higienicznego: 26 maja 2009
The date of issue of the certificate: 25th May 2009

Reprodukcje, kopiowanie, fotografowanie, skanowanie, digitalizacja Atestu Higienicznego w celach marketingowych bez zgody NIZP-PZH jest zabronione.

Kierownik Zakładu Higieny Komunalnej
[Signature]
dr Bożena Krocuska

www.pzh.gov.pl



Some Results of 750 Penwood Profile System Tests

Results of Tendency Test for Fixed Mullion Profiles



Sample		Max. Load		Longitudinal Modulus		Permanent Deflection		Observation
		kg	N	Ton	kN	mm	%*	
Penwood Composite Mixture	1	348	3414	22,9	225	-	-	Test Has Been Stopped
	2	348	3414	25,0	245	-	-	
	Average	348	3414	24,0	235	-	-	-
Steel Reinforced		284	2786	22,9	225	51	0,66	Test Has Been Stopped ²

The load applied on the screw has been recorded as the loads of stripping or breaking of the screws fixed on the surface of profiles, knowing that head of screw remained outside by 4 mm in this test.

Test Results of Screw Retention for Penwood Composite Profiles

Sample		Load Applied On Screw		Observation
		kg	N	
Mullion	1	426	4181	Screw Has Been Stripped
	2	431	4226	
	3	440	4318	
	4	450	4410	Screw Has Been Broken Off
	5	464	4548	
	Average	442	4548	-
Sash and Door Sash	1	637	6248	Screw Has Been Broken Off
	2	824	8085	
	3	712	6983	
	4	599	5880	Screw Has Been Stripped
	5	613	6018	
	Average	677	6643	-
Frame	1	454	4456	Screw Has Been Stripped
	2	436	4272	
	3	468	4594	
	4	431	4226	
	5	440	4318	
	Average	446	4373	-

Test of Screw Retention for Steel - Reinforced PVC Profiles.

Sample		Load Applied On Screw		Observation
		kg	N	
Mullion	1	482	4732	Screw Has Been Stripped
	2	454	4456	
	3	482	4732	
	4	459	4502	
	5	473	4638	
	Average	470	4612	-
Sash and Door Sash	1	347	3400	Screw Has Been Stripped
	2	361	3537	
	3	379	3721	
	4	431	4226	
	5	387	3800	
	Average	381	3737	-
Frame	1	342	3354	Screw Has Been Stripped
	2	356	3491	
	3	342	3354	
	4	384	3767	
	5	370	3629	
	Average	359	3519	-

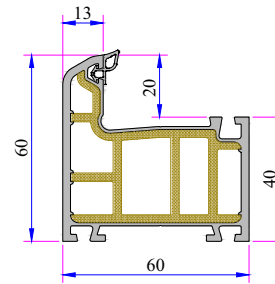

Frame Profile

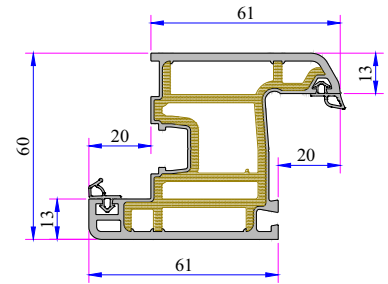

Sash Profile

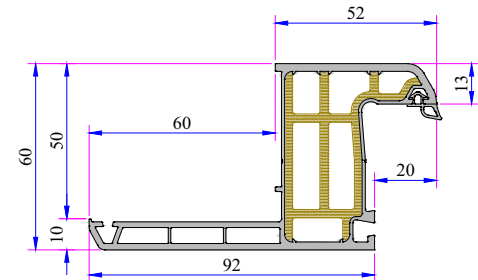

Frame With Sill Profile

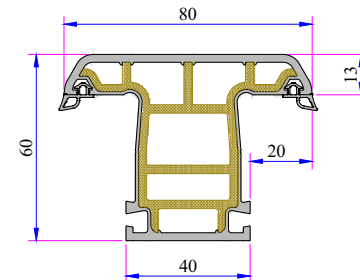

Mullion Profile

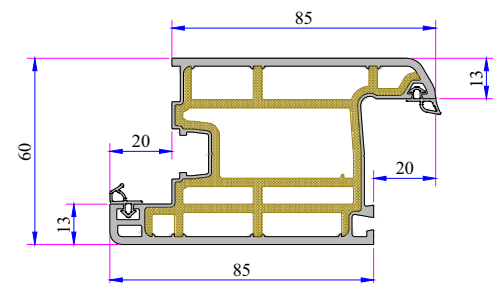

Door Sash Profile



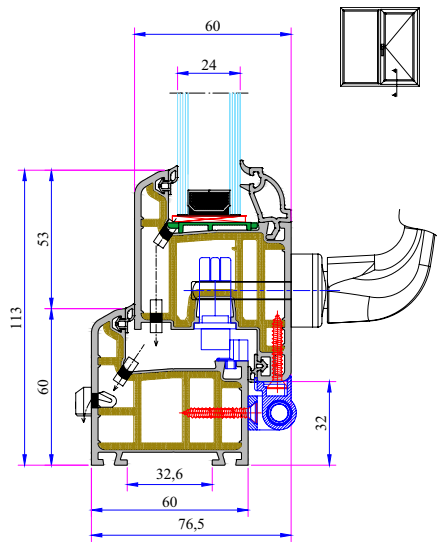

Frame - Sash Installation

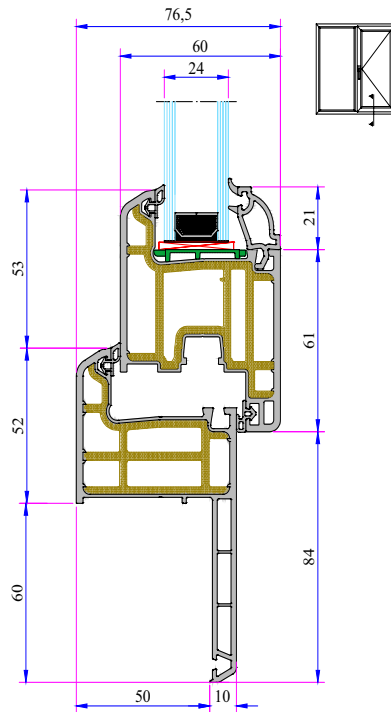

Frame With Sill - Sash Installation

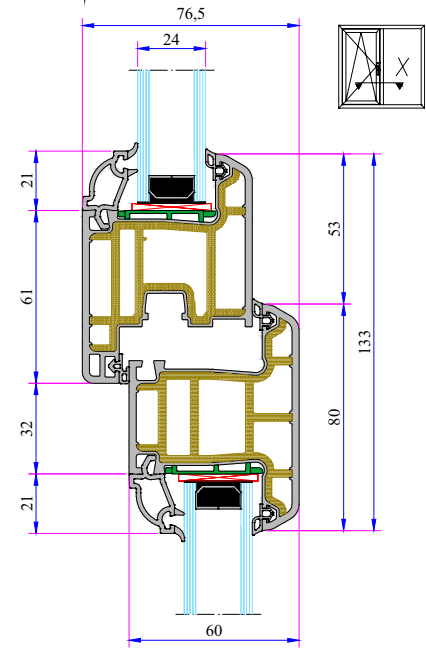

Mullion - Sash Installation

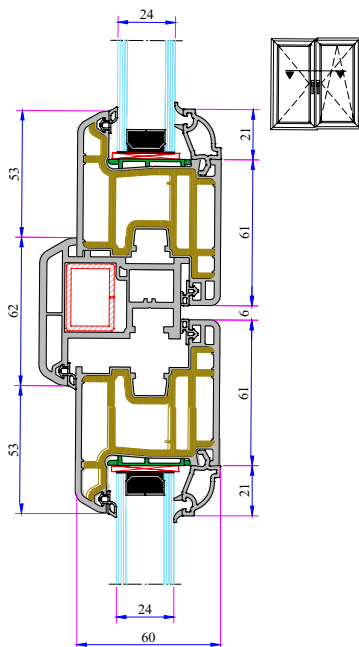

Sash - Lap Joint - Sash Installation

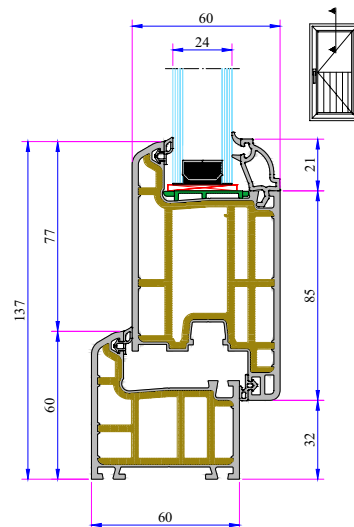

Frame - Door Sash Installation

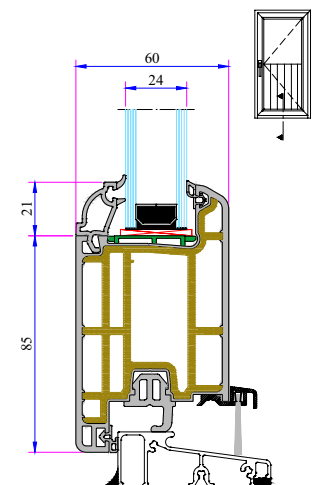

With Aluminium Threshold
Frame Door Sash Installation

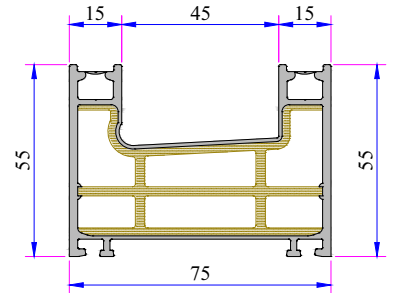

Penwood Frame Profile (Double Rail)

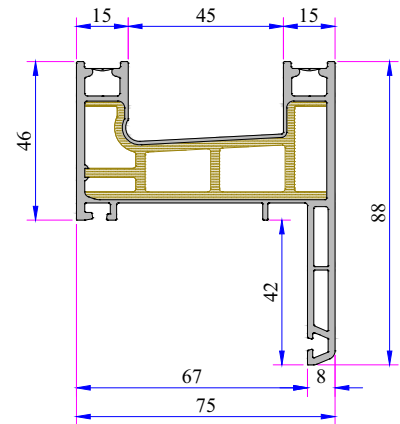

Penwood Frame Profile With Flat Sill

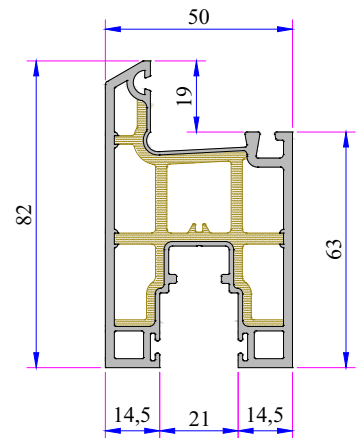

Sliding System Sash Profile



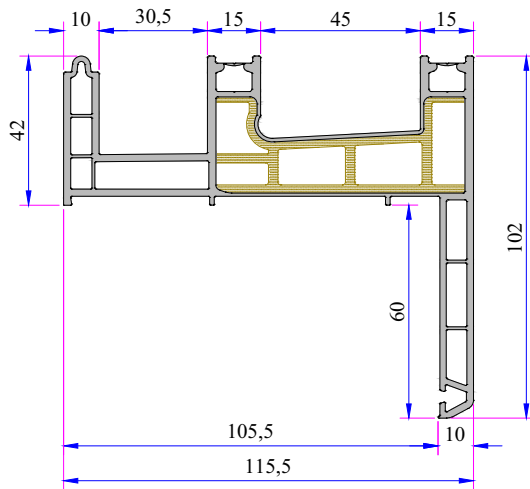

Penwood Frame With Fly-Screen&Sill

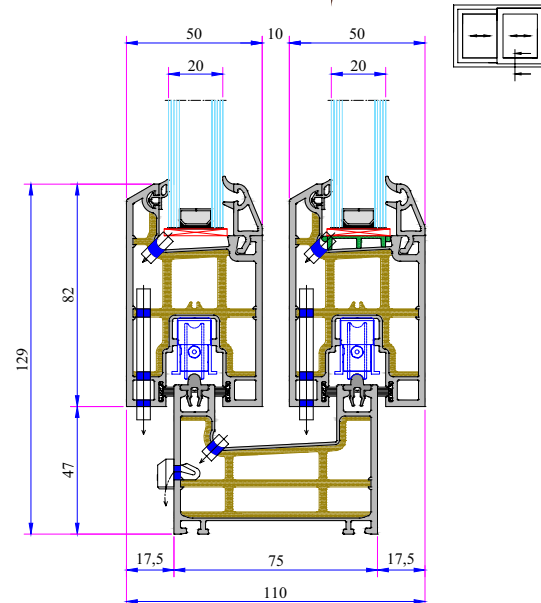

Sliding Frame Sash Double Rail Installation

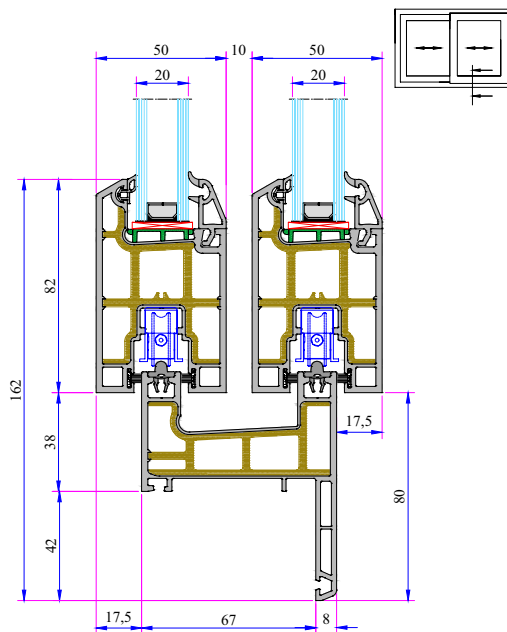

Double Sliding Frame with Sill - Sash Installation

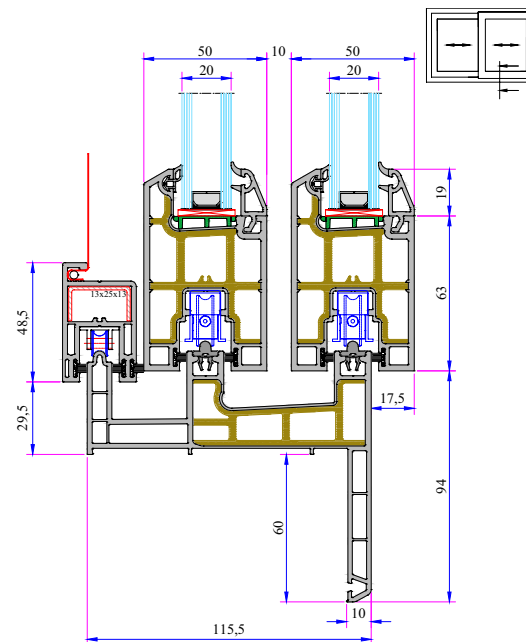

Double Sliding Frame with Sill (60mm) - Sash Installation





PENWOOD

WOOD COMPOSITE DOOR AND WINDOW SYSTEMS

www.wintechpvc.com